

I.V.A.S Industria Vernici S.p.A

Via Bellaria, 40

I-47030

San Mauro Pascoli (FC)

Italy

Tel: 01189 635 900 Fax: 01189 635 901

e-mail: enquiries@gruppoivas.co.uk

website: www.gruppoivas.com



Agrément Certificate

11/4841

Product Sheet 5

TERMOK8 EXTERNAL WALL INSULATION SYSTEMS

TERMOK8 CLASSICO EXTERNAL WALL INSULATING RENDER SYSTEMS

This Agrément Certificate Product Sheet⁽¹⁾ relates to the Termok8 Classico External Wall Insulating Render Systems, comprising mechanically-fixed white/grey expanded polystyrene (EPS), phenolic foam (PHS) or polyisocyanurate (PIR) insulation boards, with supplementary adhesive and reinforced render and slip finishes. The systems are suitable for use on the outside of external walls in new and existing domestic and non-domestic buildings.

(1) Hereinafter referred to as 'Certificate'.

CERTIFICATION INCLUDES:

- factors relating to compliance with Building Regulations where applicable
- factors relating to additional non-regulatory information where applicable
- independently verified technical specification
- assessment criteria and technical investigations
- design considerations
- installation guidance
- regular surveillance of production
- formal three-yearly review.

KEY FACTORS ASSESSED

Thermal performance — the systems can be used to improve the thermal performance of external walls and can contribute to meeting the requirements of the national Building Regulations (see section 6).

Strength and stability — the systems can adequately resist wind loads and have sufficient resistance to impact damage (see section 7).

Behaviour in relation to fire — the systems have reaction to fire classifications of B-s1, d0 and B-s2, d0 in accordance with BS EN 13501-1 : 2007 (see section 8).

Risk of condensation — the systems can contribute to limiting the risk of interstitial and surface condensation (see section 11).

Durability — when installed and maintained in accordance with the Certificate holder's recommendations and the terms of the Certificate, the systems will remain effective for at least 30 years. The durability can be extended to 60 years by using different fixings and following a planned inspection and an effective maintenance schedule as described in sections 12 and 13.



The BBA has awarded this Certificate to the company named above for the systems described herein. These systems have been assessed by the BBA as being fit for their intended use provided they are installed, used and maintained as set out in this Certificate.

On behalf of the British Board of Agrément

Brian Chamberlain

Head of Approvals — Engineering

Claire Curtis-Thomas

Chief Executive

Date of First issue: 19 December 2014

The BBA is a UKAS accredited certification body — Number 113. The schedule of the current scope of accreditation for product certification is available in pdf format via the UKAS link on the BBA website at www.bbacerts.co.uk

Readers are advised to check the validity and latest issue number of this Agrément Certificate by either referring to the BBA website or contacting the BBA direct.

British Board of Agrément

Bucknalls Lane

Watford

Herts WD25 9BA

tel: 01923 665300

fax: 01923 665301

clientservices@bba.star.co.uk

www.bbacerts.co.uk

©2014

Regulations

In the opinion of the BBA, TermoK8 Classico External Wall Insulating Render Systems, if installed, used and maintained in accordance with the provisions of this Certificate, can satisfy, or contribute to satisfying, the relevant requirements of the following Building Regulations (the presence of a UK map indicates that the subject is related to the Building Regulations in the region or regions of the UK depicted):



The Building Regulations 2010 (England and Wales) (as amended)

Requirement:	A1	Loading
Comment:		The systems can sustain and transmit wind loads to the substrate wall. See section 7.4 of this Certificate.
Requirement:	B4(1)	External fire spread
Comment:		The systems can satisfy this Requirement. See sections 8.1 to 8.4 of this Certificate.
Requirement:	C2(b)	Resistance to moisture
Comment:		The systems provide a degree of protection against rain ingress. See sections 4.4 and 10.1 of this Certificate.
Requirement:	C2(c)	Resistance to moisture
Comment:		The systems contribute to minimising the risk of interstitial and surface condensation. See sections 11.1, 11.2 and 11.4 of this Certificate.
Requirement:	L1(a)(i)	Conservation of fuel and power
Comment:		The systems can contribute to satisfying this Requirement. See sections 6.2 and 6.3 of this Certificate.
Regulation:	7	Materials and workmanship
Comment:		The systems are acceptable. See section 13.1 and the <i>Installation</i> part of this Certificate.
Regulation:	26	CO₂ emission rate for new buildings
Regulation:	26A	Fabric energy efficiency rates for new dwellings (applicable to England only)
Regulation:	26A	Primary energy consumption rates for new buildings (applicable to Wales only)
Regulation:	26B	Fabric performance values for new dwellings (applicable to Wales only)
Comment:		The systems can contribute to satisfying these Regulations. See sections 6.2 and 6.3 of this Certificate.



The Building (Scotland) Regulations 2004 (as amended)

Regulation:	8(1)(2)	Durability, workmanship and fitness of materials
Comment:		The systems can contribute to a construction satisfying this Regulation. See sections 12 and 13.1 and the <i>Installation</i> part of this Certificate.
Regulation:	9	Building standards applicable to construction
Standard:	1.1	Structure
Comment:		The systems can sustain and transmit wind loads to the substrate wall. See section 7.4 of this Certificate.
Standard:	2.6	Spread to neighbouring buildings
Comment:		The systems can meet this Standard, with reference to clauses 2.6.4 ⁽¹⁾⁽²⁾ , 2.6.5 ⁽¹⁾ and 2.6.6 ⁽²⁾ . See sections 8.1 to 8.6 of this Certificate.
Standard:	2.7	Spread on external walls
Comment:		The systems can satisfy this Standard, and are acceptable for use more than one metre from a boundary, with reference to clauses 2.7.1 ⁽¹⁾⁽²⁾ and 2.7.2 ⁽²⁾ , and Annex 2A ⁽¹⁾ . See sections 8.1 to 8.6 of this Certificate.
Standard:	3.10	Precipitation
Comment:		The systems can contribute to a construction satisfying this Standard, with reference to clauses 3.10.1 ⁽¹⁾⁽²⁾ and 3.10.2 ⁽¹⁾⁽²⁾ . See sections 4.4 and 10.1 of this Certificate.
Standard:	3.15	Condensation
Comment:		The systems can contribute to satisfying this Standard, with reference to clauses 3.15.1 ⁽¹⁾⁽²⁾ , 3.15.4 ⁽¹⁾⁽²⁾ and 3.15.5 ⁽¹⁾⁽²⁾ . See sections 11.3 and 11.4 of this Certificate.
Standard:	6.1(b)	Carbon dioxide emissions
Standard:	6.2	Buildings insulation envelope
Comment:		The systems can contribute to satisfying these Standards, with reference to clauses (or parts of) 6.1.1 ⁽¹⁾ , 6.1.2 ⁽¹⁾⁽²⁾ , 6.1.3 ⁽¹⁾⁽²⁾ , 6.1.6 ⁽¹⁾ , 6.1.10 ⁽²⁾ , 6.2.1 ⁽¹⁾⁽²⁾ , 6.2.3 ⁽¹⁾ , 6.2.4 ⁽²⁾ , 6.2.6 ⁽¹⁾ , 6.2.7 ⁽¹⁾ , 6.2.8 ⁽²⁾ , 6.2.9 ⁽¹⁾⁽²⁾ , 6.2.10 ⁽¹⁾ , 6.2.11 ⁽¹⁾ , 6.2.12 ⁽²⁾ , and 6.2.13 ⁽¹⁾⁽²⁾ . See sections 6.2 and 6.3 of this Certificate.
Standard:	7.1(a)(b)	Statement of sustainability
Comment:		The systems can contribute to satisfying the relevant requirements of Regulation 9, Standards 1 to 6, and therefore will contribute to a construction meeting the bronze level of sustainability as defined in this Standard. In addition, the systems can contribute to a construction meeting a higher level of sustainability as defined in this Standard with reference to clauses 7.1.4 ⁽¹⁾⁽²⁾ [Aspect 1 ⁽¹⁾⁽²⁾ and 2 ⁽¹⁾], 7.1.6 ⁽¹⁾⁽²⁾ [Aspect 1 ⁽¹⁾⁽²⁾ and 2 ⁽¹⁾] and 7.1.7 ⁽¹⁾⁽²⁾ [Aspect 1 ⁽¹⁾⁽²⁾]. See section 6.2 of this Certificate.
Regulation:	12	Building standards applicable to conversions
Comment:		All comments given for the systems under Regulation 9, Standards 1 to 6, also apply to this Regulation, with reference to clause 0.12.1 ⁽¹⁾⁽²⁾ and Schedule 6 ⁽¹⁾⁽²⁾ . (1) Technical Handbook (Domestic). (2) Technical Handbook (Non-Domestic).



The Building Regulations (Northern Ireland) 2012

Regulation:	23	Fitness of materials and workmanship
Comment:		The system is acceptable. See section 13.1 and the <i>Installation</i> part of this Certificate.
Regulation:	28	Resistance to moisture and weather
Comment:		Walls insulated with the system will satisfy this Regulation. See sections 4.4 and 10.1 of this Certificate.
Regulation:	29	Condensation
Comment:		Walls insulated with the system will satisfy the requirements of this Regulation. See section 11.4 of this Certificate.
Regulation:	30	Stability
Comment:		The system can sustain and transmit wind loads to the substrate wall. See section 7.4 of this Certificate.
Regulation:	36(a)	External fire spread
Comment:		The system has a low risk surface and can satisfy this Regulation. See sections 8.1 to 8.4 of this Certificate.
Regulation:	39(a)(i)	Conservation measures
Regulation:	40	Target carbon dioxide emission rate
Comment:		The system can contribute to satisfying these Regulations. See sections 6.2 and 6.3 of this Certificate.

Construction (Design and Management) Regulations 2007

Construction (Design and Management) Regulations (Northern Ireland) 2007

Information in this Certificate may assist the client, CDM co-ordinator, designer and contractors to address their obligations under these Regulations.

See section: 3 *Delivery and site handling* (3.2 and 3.4) of this Certificate.

Additional Information

NHBC Standards 2014

NHBC accepts the use of TermoK8 Classico External Wall Insulating Render Systems, provided they are installed, used and maintained in accordance with this Certificate, in relation to *NHBC Standards, Part 6 Superstructure, Chapter 6.9 Curtain walling and cladding*.

Technical Specification

1 Description

1.1 TermoK8 Classico Minerale External Wall Insulation Systems are mechanically fixed systems with supplementary adhesive, comprising EPS, PHS or PIR insulation with reinforced, lightweight, coloured render.

1.2 For a 30 year durability, the system is primarily fixed through the insulation boards, with the reinforcing mesh embedding immediately, and the surface smoothed with a trowel. For a 60-year durability application, additional mechanical fixings are applied through the insulation and basecoat while the basecoat is wet, before the mesh patches are applied over the fixing heads and fully embedded. A further layer of basecoat render is applied over the embedded reinforcing mesh to achieve the required overall thickness. When the basecoat is dry, the selected finishes are applied (see Figure 1 for both 30- and 60-year applications, and section 16).

Table 1 TermoK8 Classico External Wall Insulation Render System summary

Components	Product	
	Option 1	Option 2
Adhesive	Klebocem/Klebocem Minerale	Klebocem Grosso
Insulations	EPS (white or grey), PHS, PIR	EPS (white or grey), PIR ⁽¹⁾ , PHS ⁽¹⁾
Basecoat	Klebocem Klebocem Minerale	Klebocem Grosso
Reinforcement		Armatex C 1
Top coats	–	Brick effect base render Dash receiver Acrylic brick-slips adhesive
Finishes and/or Decorative profiles	TermoK8 Rivatone Plus TermoK8 Rivatone Idrosiliconico Plus	Brick effect render top ⁽²⁾ Spar dry-dash aggregate Acrylic brick-slip

(1) This insulation can only be used with mechanical fixings applied through the mesh.

1.3 The systems are made up of the following components:

Supplementary adhesive

- Klebocem, Klebocem Minerale and Klebocem Grosso — grey or white cement-based powder with particle size of 0.6 mm for Klebocem and Klebocem Minerale, and 1.2 mm for Klebocem Grosso, organic content 3.1%, mixed with approximately 24% water by volume to form a paste and used to fix the insulation boards to the substrate and applied to an approximate thickness of 10 mm.

Insulation

- expanded polystyrene 120 (EPS) insulation boards — 1200 mm by 600 mm, in a range of thicknesses from 30⁽¹⁾ mm to 300 mm, with a nominal density of 20 kg·m⁻³, minimum compressive strength of 120 kN·m⁻² and tensile strength perpendicular to the faces of 200 kN·mm⁻². Boards are manufactured to comply with the requirements of BS EN 13163 : 2012
- white/grey expanded polystyrene 70 (EPS) insulation boards — 1200 mm by 600 mm, in a range of thicknesses from 30⁽¹⁾ mm to 300 mm, with a nominal density of 20 kg·m⁻³, minimum compressive strength of 70 kN·m⁻² and tensile strength perpendicular to the faces of 150 kN·mm⁻². Boards are manufactured to comply with the requirements of BS EN 13163 : 2012
- phenolic foam (PHS) insulation boards — 1200 mm by 600 mm, in a range of thicknesses from 20⁽¹⁾ mm to 200 mm, faced on both sides with a 0.3 mm layer of glassfibre, with a nominal density of 35 kg·m⁻³, minimum compressive strength of 120 kN·m⁻² and tensile strength perpendicular to the faces of 50 kN·mm⁻². Boards are manufactured to comply with the requirements of BS EN 13166 : 2012
- polyisocyanurate (PIR) tissue-faced insulation boards — 1200 mm by 600 mm, in a range of thicknesses from 50 mm to 150 mm, with a nominal density of 40 kg·m⁻³, minimum compressive strength of 120 kN·mm⁻², and a tensile strength perpendicular to the faces of 80 kN·mm⁻². The boards are manufactured to comply with BS EN 13165 : 2012.

(1) Boards of 20 mm to 50 mm thicknesses are available for use in window reveals.

Mechanical fixings

- TermoK8 fixings — a range of anchorage plugs⁽¹⁾, with an anchorage depth of a least 25 mm, approved and supplied by the Certificate holder selected from:
 - Ejot NT U — high-density polyethylene (PE-HD) anchor sleeve and cap or insulation cover with a steel or stainless steel pin
 - Ejot STR U — high-density polyethylene (PE-HD) or polyamide PA anchor sleeve and cup or insulation cover with a steel or stainless steel pin
 - SDK U — high-density polyethylene (PE-HD) or polyamide PA anchor sleeve and cap or insulation cover with steel or stainless steel centre pin.
 - H1 Eco — high-density polyethylene anchor sleeve and PA fixing mounting plug with galvanized steel centre pin

(1) Other fixings may be used provided they can be demonstrated to have equal or higher pull out and plate stiffness and material characteristics.

(2) Polyethylene, PE-HD or polyamide anchor sleeve must have a stainless steel pin to achieve 60-year durability performance.

Basecoats

- Klebocem and Klebocem Minerale — grey or white cement-based powder with particle size of 0.6 mm, mixed with approximately 24% water by volume to form a paste. Applied to a minimum thickness of 7 mm
- Klebocem Grosso — grey or white cement-based powder with particle size of 1.2 mm, mixed with approximately 5 litres of clean water per 25 kg bag to form a paste. Applied to a minimum thickness of 7 mm.

Reinforcement

- Armatex C1 — a woven alkali-resistant glassfibre reinforcement mesh, cell size approximately 3.0 mm by 3.5 mm with a polymer coating and a nominal weight of 160 g·m⁻²

Primer

- Acrylic primer — a water-based single-component primer, supplied in liquid form for use with acrylic decorative finish
- Silicone primer — a water-based single-component primer, supplied in liquid form for use with silicone decorative finish
- Acrylic brick-slip primer — a water based single-component, primer, supplied in liquid form, for use with acrylic brick-slips.

Top coats

- Brick effect base render — a polymer-based powder containing cement, for mixing with 4 to 5 litres of clean water. Applied to an approximately 6 mm thickness
- Dash receiver — light-coloured top coat, comprising limestone sand conforming to BS EN 13139 : 2002, cement conforming to BS EN 197-1 : 2011 and additives. Supplied as a powder to which clean water is added, and applied to a 5 mm thickness
- Acrylic brick-slips adhesive — organic-bound, polymer dispersion water-based ready-to-use adhesive and joint mortar. Supplied pre-coloured in white, light grey, and brown, and applied to a 2 mm thickness. For the application of the acrylic brick-slips

Finishes

- TermoK8 Rivatone Plus — acrylic resin-based, ready-to-use granular paste, applied to a 1.5 mm to 3 mm thickness, with a coverage rate of approximately 1 m² per 2.5 kg to 3.5 kg. Available in a range of colours
- TermoK8 Rivatone Idrosiliconico Plus — silicone resin-based, ready-to-use granular pastes, applied to a 1.2 mm to 3 mm thickness, with a coverage rate of approximately 1 m² per 2.5 kg to 3.5 kg. Available in a range of colours

- Brick effect render top — polymer-based powder, containing cement, for mixing with 4 to 5 litres of clean water, and applied to an approximately 2 mm to 6 mm thickness.

Decorative profiles

- Spar dry-dash aggregate — available in a range of colours to suit the dash receiver, 3 mm to 8 mm aggregate size
- Acrylic brick-slip — pre-coloured handmade, 4 mm to 6 mm thick, 65 mm wide by 215 mm long, weather-resistant acrylic brick-slips.

Figure 1 TERMOK8 Classico External Wall Insulation System

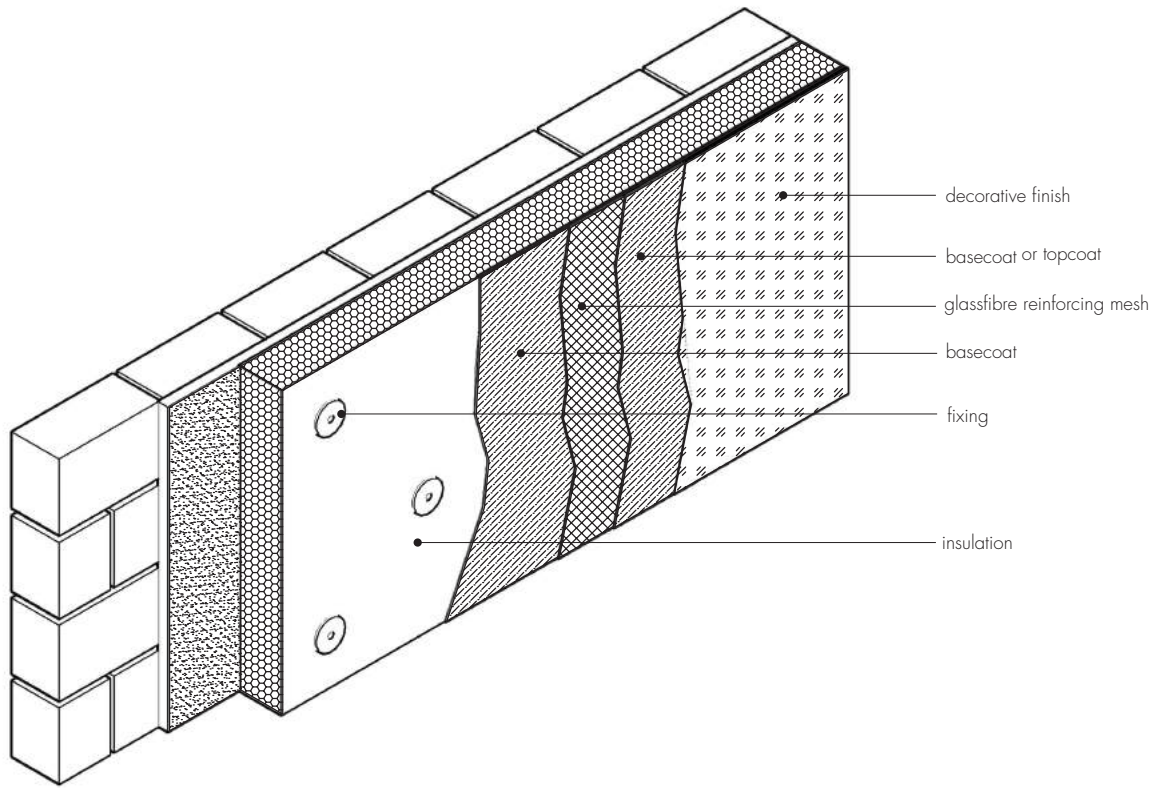

30 year durability

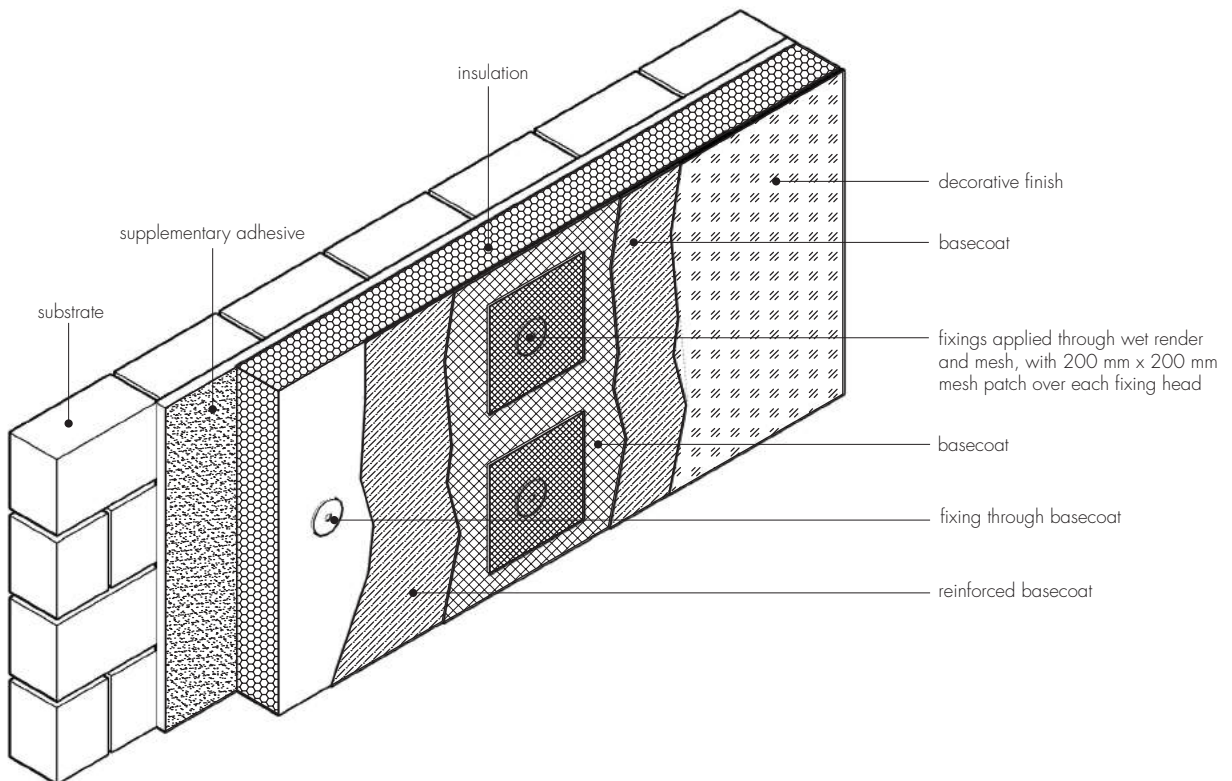

60 year durability

1.4 Ancillary materials also used with the systems but outside the scope of this Certificate:

- range of aluminium, PVC-U or stainless steel profiles, comprising:
 - base profile
 - edge profile
 - corner profile
 - render stop profile
 - movement and expansion joint
- profile connectors and fixings
- fungicidal wash, water-based masonry cleaner and steriliser containing biocides
- expansion foam
- sealants — silicone or mastic silicone in accordance with BS EN ISO 11600 : 2003
- mineral wool fire barrier
- cement or polymer-based mortar to repair the substrate surface.

2 Manufacture

2.1 Components are manufactured by the Certificate holder or bought in from suppliers, to an agreed specification.

2.2 As part of the assessment and ongoing surveillance of product quality, the BBA has:

- agreed with the manufacturer the quality control procedures and product testing to be undertaken
- assessed and agreed the quality control operated over batches of incoming materials
- monitored the production process and verified that it is in accordance with the documented process
- evaluated the process for management of nonconformities
- checked that equipment has been properly tested and calibrated
- undertaken to carry out the above measures on a regular basis through a surveillance process, to verify that the specifications and quality control operated by the manufacturer are being maintained.

2.3 The systems are marketed in the UK by: Aliva UK, 1210 Parkview, Arlington Business Park, Theale, Berkshire RG7 4TY. Tel: 01189 635 900, e-mail: enquiries@gruppoivas.co.uk.

3 Delivery and site handling

3.1 The insulation is delivered to site shrink-wrapped in polythene packs bearing the manufacturer's and product identification marks and batch numbers.

3.2 The other components are delivered to site in the quantities and packages as listed in Table 2. Each package carries the manufacturer's and product's identification marks and batch number.

Table 2 Components — supply details⁽¹⁾

Component	Quantity/weight
Adhesive (grey or white)	25 kg bag
Klebocem basecoats	25 kg bag
Primers	10/15 L plastic drum
Armatex C1 reinforcing mesh	1 m x 50 m roll
TermoK8 Rivatone Plus	25 kg plastic tub
TermoK8 Rivatone Idrosiliconico Plus	25 kg plastic tub
Brick effect render top	25 kg bag
Brick effect render base	25 kg bag
Dash receiver	25 kg bag
Spar dash aggregate	25 kg bag
Acrylic brick-slips adhesive	20 kg bucket
Acrylic brick slips	100 per box
Mechanical fixings	boxed by manufacturer

(1) Ancillary items, such as aluminium profiles or fixings, are supplied boxed as appropriate.

3.3 The boards must be stored on a firm, clean, level base, off the ground and under cover until required for use. Care must be taken when handling to avoid damage.

3.4 The boards must be protected from prolonged exposure to sunlight, either by storing opened packs under cover or re-covering with opaque polythene sheeting. Care must be taken to avoid contact with solvents or materials containing volatile organic components. The boards must not be exposed to open flame or other ignition sources.

3.5 The adhesive, basecoat and topcoats and all cementitious materials must be stored in dry conditions within 5°C and 30°C, off the ground and protected from moisture. Contaminated material must be discarded.

Assessment and Technical Investigations

The following is a summary of the assessment and technical investigations carried out on TermoK8 Classico External Wall Insulating Render Systems.

Design Considerations

4 General

4.1 TermoK8 Classico External Wall Insulating Render Systems, when installed in accordance with this Certificate, are effective in reducing the thermal transmittance (U value) of the walls of new and existing buildings. It is essential that the detailing techniques specified in this Certificate are carried out to a high standard, if the ingress of water into the insulation is to be avoided and the full thermal benefit obtained from treatment with the systems.

4.2 For improved thermal/carbon-emissions performance, the designer should consider additional/alternative fabric and/or services measures.

4.3 The systems are for application to the outside of external walls of masonry, or dense or no-fines concrete construction, on new or existing domestic and non-domestic buildings (with or without existing render) up to 18 metres in height. Prior to the installation of the systems, wall surfaces should comply with section 14 of this Certificate.

4.4  New walls subject to national Building Regulations should be constructed in accordance with the relevant recommendations of:

- BS EN 1996-2 : 2006, in that the designer should select a construction appropriate to the local wind-driven rain index, paying due regard to the design detailing, workmanship and materials to be used
- BS 8000-3 : 2001.

4.5 Other new buildings not subject to regulatory requirements should also be built in accordance with the standards identified in section 4.4.

4.6 The systems will improve the weather resistance of a wall and provide a decorative finish. However, they should only be installed where there are no signs of dampness on the inner surface of the wall other than those caused solely by condensation.

4.7 The effect of the installation of the insulation systems on the acoustic performance of a construction is outside the scope of this Certificate.

4.8 The fixing of rainwater goods, satellite dishes, clothes lines, hanging baskets and similar items is outside the scope of this Certificate.

4.9 External plumbing should be removed before installation and alterations made to underground drainage, where appropriate, to accommodate repositioning of the plumbing to the finished face of the system.

4.10 It is essential that the systems are installed and maintained in accordance with the conditions set out in this Certificate.

5 Practicability of installation

The systems should only be installed by specialised contractors who have successfully undergone training and registration by the Certificate holder (see section 14).

Note: The BBA operates a UKAS Accredited Approved Installer Scheme for external wall insulation; details of approved installer companies are included on the BBA's website (www.bbacerts.co.uk).

6 Thermal performance

6.1 Calculations of thermal transmittance (U value) should be carried out in accordance with BS EN ISO 6946 : 2007 and BRE Report BR 443 : 2006, using the declared thermal conductivities values (λ_D) of the insulations given in Table 3.

Table 3 Declared thermal conductivities values (λ_D) and available thicknesses

Insulation type	Thickness (mm)	Thermal conductivity ($W \cdot m^{-1} \cdot K^{-1}$)
Expanded polystyrene (EPS) 120	30 to 300	0.036
Expanded polystyrene (EPS) 70	30 to 300	0.038
Grey expanded polystyrene (EPS) 70	30 to 300	0.032
Phenolic foam (Phenolic)	20 to 45	0.021
	45 to 200	0.020
PIR (glass tissue facing) :	50 to 80	0.027
	80 to 120	0.026
	120 to 150	0.025



6.2 The U value of a completed wall will depend on the insulation type and thickness, the type and number of fixings, and the insulating value of the substrate masonry and its internal finish. Calculated U values for sample construction in accordance with the national Building Regulations are given in Table 4, and are based on the thermal conductivities given in Table 3.

Table 4 Insulation thickness required to achieve design U values⁽¹⁾⁽²⁾⁽³⁾

U value (W·m ⁻² ·K ⁻¹) ⁽⁴⁾	Thickness of insulation (mm)									
	215 mm brickwork, $\lambda = 0.56 \text{ W}\cdot\text{m}^{-1}\cdot\text{K}^{-1}$					200 mm dense blockwork, $\lambda = 1.75 \text{ W}\cdot\text{m}^{-1}\cdot\text{K}^{-1}$				
	EPS 120	EPS 70	Grey EPS	PHS	PIR	EPS 120	EPS 70	Grey EPS	PHS	PIR
0.18	190	200	170	105	140	200	210	180	115	140
0.19	180	190	160	105	130	190	200	170	105	130
0.25	130	140	120	75	100	140	150	130	85	100
0.26	130	130	110	75	90	140	140	120	75	100
0.28	120	120	100	65	90	120	130	110	75	90
0.30	110	110	100	65	80	120	120	100	65	80
0.35	90	90	80	55	80	100	100	90	55	70

- (1) Wall construction inclusive of 13 mm plaster ($\lambda = 0.57 \text{ W}\cdot\text{m}^{-1}\cdot\text{K}^{-1}$), brickwork (protected) with 17.1% mortar or dense blockwork with 6.7% mortar ($\lambda = 0.88 \text{ W}\cdot\text{m}^{-1}\cdot\text{K}^{-1}$). An adhesive layer of 5 mm thick with $\lambda = 1$ covering 30% of the area is also included, and a board emissivity of 0.9, together with an external render thickness of 7.2 mm with $\lambda = 1 \text{ W}\cdot\text{m}^{-1}\cdot\text{K}^{-1}$.
- (2) Calculations based on a system that included 7 stainless steel fixings per square metre with a point thermal transmittance (χ_p) of $0.002 \text{ W}\cdot\text{m}^{-1}\cdot\text{K}^{-1}$ per steel pin. Use of other types of fixings should be calculated in accordance with BS EN ISO 6946 : 2007. A gap correction (ΔU) of zero is assumed.
- (3) Based upon incremental insulation thickness of 10 mm.
- (4) When applying the maximum available insulation thickness, these walls can achieve U values from 0.11 to $0.17 \text{ W}\cdot\text{m}^{-2}\cdot\text{K}^{-1}$ depending on insulation and wall type.

6.3 The systems can maintain, or contribute to maintaining, continuity of thermal insulation at junctions between external walls and other elements. Details shown in section 16 will allow use of the default ψ -values (Psi) for Accredited Construction Details in Emission Rate calculations to SAP 2009 or the Simplified Building Energy Model (SBEM). Detailed guidance can be found in the documents supporting the national Building Regulations.

7 Strength and stability

General

7.1 When installed on suitable walls, the systems can adequately transfer to the wall the self-weight and negative (suction) and positive (pressure) wind loads normally experienced in the United Kingdom.

7.2 Positive wind load is transferred to the substrate wall directly via bearing and compression of the render and insulation.

7.3 Negative wind pressure is resisted by the bond between each component. The insulation boards are retained by the external wall insulation system anchors.



7.4 The wind loads on the wall should be calculated in accordance with BS EN 1991-1-4 : 2005. Special consideration should be given to locations with high wind-load pressure coefficients, as additional fixings may be necessary. In accordance with BS EN 1990 : 2002, it is recommended that a load factor of 1.5 is used to determine the ultimate wind load to be resisted by the system.

7.5 Assessment of structural performance for individual installations should be carried out by a suitably qualified and experienced individual to confirm that:

- the substrate wall has adequate strength to resist the additional loads that may be applied as a result of installing the system, ignoring any positive contribution that may occur from the system
- the proposed system (with associated fixing layout) provides adequate resistance to negative wind loads
- an appropriate number of site-specific pull out tests have been conducted on the substrate of the building to determine the minimum resistance to failure of the fixings. The characteristic pull-out resistance should be determined in accordance with the guidance given in ETAG 014 : 2011.

7.6 The number and centre of fixings should be determined by the system designer. Provided the substrate wall is suitable and appropriate fixing is selected, the mechanical fixings will adequately support and transfer the weight of the render insulation system to the substrate wall at the minimum spacing given in this Certificate.

7.7 Typical characteristic pull-out strengths for the fixings taken from the European Technical Approval (ETA) are given in Table 5; however, these values are dependent on the substrate and the fixing must be selected to suit the loads and substrate concerned.

Table 5 Fixings — typical characteristic pull-out strengths

Fixing type	ETA number	Substrate	Drill diameter (mm)	Embedment depth (mm)	Typical pull-out strength (kN)
Ejot NT U	05/0009	Concrete/clay brickwork	8	25	1.2/1.5
Ejot STR U Ejot SDK U	04/0023	Concrete/clay brickwork	8	25	1.5/1.5
H1 Eco	11/0192	Concrete/clay brickwork	8	25	0.9/0.9

(1) Values are determined in accordance with ETAG 014 : 2011 and are dependent on the substrate.

7.8 The design pull-through resistance data given in Table 6 is the result of calculations based upon pull through resistances determined by BBA from tests on anchors with 60 mm diameters.

Table 6 Typical calculation to establish the pull-through resistances

	EPS 70 (white/grey)	EPS 120	PHS	PIR	
Fixings plate diameter (mm)	60				
Fixings types	see Table 5				
Insulation thickness (mm)	>60	>100	>60	>60	>60
Characteristic pull-through resistance ⁽¹⁾ per fixing (N)	415	698	450	836	698
Factor of safety ⁽²⁾	2.5				
Design pull-through resistance per fixing (N)	166	279	180	335	359

(1) Characteristic pull-through resistance of insulation over the head of the fixing, in accordance with BS EN 1990 : 2002, Annex D7.2.

(2) The safety factor of 2.5 is based on the assumption that all insulation boards are quality controlled and tested to establish tensile strength perpendicular to the face of the board, and failure mode.

Impact resistance

7.9 Hard body impact tests were carried out in accordance with ETAG 004 : 2013. The systems are suitable for the use Categories listed in Table 7 of this Certificate.

Table 7 TermoK8 Classic External Wall Insulation System — impact resistance

	Category ⁽¹⁾
Rendering system: Basecoat + finishing coats indicated below	Single-layer mesh
Klebocem and Klebocem Minerale + TermoK8 Rivatone Plus Klebocem and Klebocem Minerale + TermoK8 Rivatone Idrosiliconico Plus	II
Klebocem Grosso + Brick effect render	III
Klebocem Grosso + Dash receiver + Spar dash aggregate	I
Klebocem Grosso + Acrylic brick slips adhesive + Acrylic brick slips	II

(1) The use categories are defined in ETAG 004 : 2013 as:

- Category I — a zone readily accessible at ground level to the public and vulnerable to hard body impacts but not subjected to abnormally rough use
- Category II — a zone liable to impacts from thrown or kicked objects, but in public locations where the height of the system will limit the size of the impact; or at lower levels where access to the building is primarily to those with some incentive to exercise care
- Category III — a zone not likely to be damaged by normal impacts caused by people or by thrown or kicked objects.

8 Behaviour in relation to fire

 8.1 The reaction to fire classification is either B-s1, d0 or B-s2, d0, in accordance with BS EN 13501-1 : 2007. See Table 8 below.

Table 8 Reaction to fire classifications

	Classification ⁽¹⁾
Rendering system: Basecoat + finishing coats indicated below	
Klebocem and Klebocem Minerale + TermoK8 Rivatone Plus (using PHS insulation) Klebocem and Klebocem Minerale + TermoK8 Rivatone Idrosiliconico Plus (using PHS insulation)	B-s1, d0
Klebocem and Klebocem Minerale + TermoK8 Rivatone Plus Klebocem and Klebocem Minerale + TermoK8 Rivatone Idrosiliconico Plus	B-s2, d0
Klebocem Grosso + Brick effect render base + Brick effect render top	B-s2, d0
Klebocem Grosso + Dash receiver + Spar dash aggregates	B-s2, d0
Klebocem Grosso + Acrylic brick slips adhesive + Acrylic brick slips	B-s2, d0

8.2 The fire classification applies to the full range of thicknesses and colours covered by this Certificate (when the organic content of the basecoat and finishing coat is a maximum of 3.1% and 9.4% respectively).

8.3 The systems are restricted for use in buildings up to 18 metres in height.

8.4 For houses in Scotland, and for all buildings in England and Wales and Northern Ireland, the systems are considered suitable for use on, or at any distance from, the boundary.



8.5 For flats and maisonettes and non-domestic building in Scotland, the systems are suitable only for use more than one metre from the boundary.

8.6 The systems are not classified as 'non-combustible', therefore calculations for unprotected areas may apply dependent on the fire resistance characteristics of the wall.

8.7 For application to second storey walls and above, it is recommended that the designer considers at least one stainless steel fixing per square metre and fire barriers in line with compartment walls and floors as advised in BRE Report BR 135 : 2013 (see Figure 2 of this Certificate).

Figure 2 Fire barrier

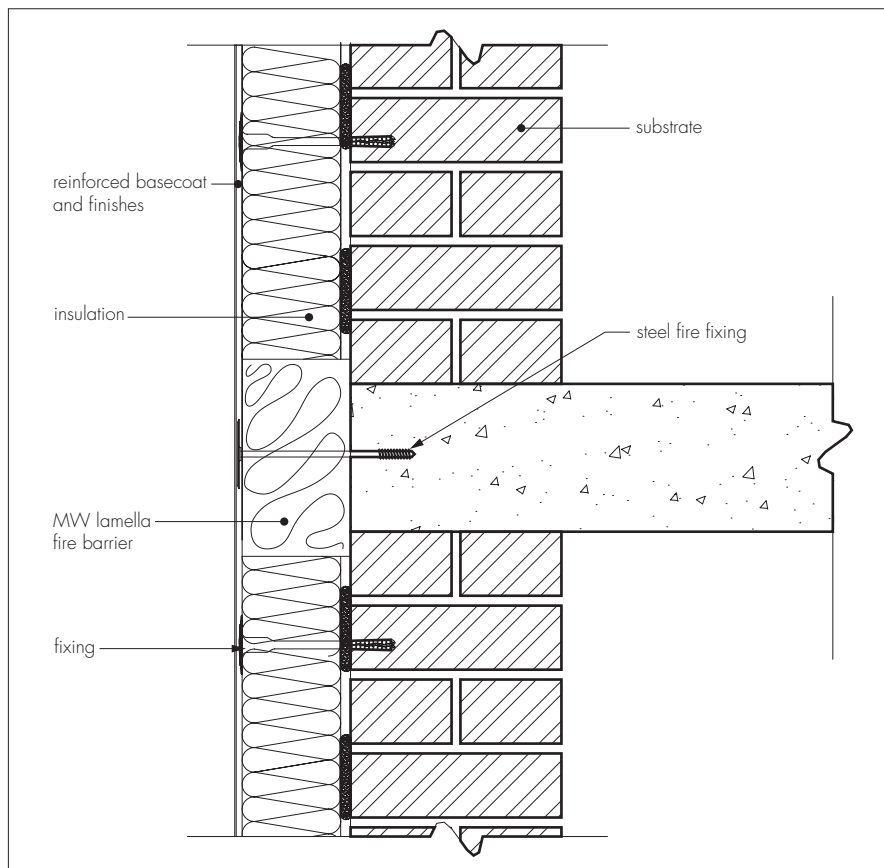

9 Proximity of flues and appliances

When the systems are installed in close proximity to certain flue pipes the relevant provisions of the national Building Regulations should be met:

England and Wales — Approved Document J

Scotland — Mandatory Standard 3.19, clause 3.19.4⁽¹⁾⁽²⁾

(1) Technical Handbook (Domestic).

(2) Technical Handbook (Non-Domestic).

Northern Ireland — Technical Booklet L.

10 Water resistance



10.1 The systems will provide a degree of protection against water ingress. However, care should be taken to ensure that walls are adequately watertight prior to application of the system. The systems must only be installed where there is no sign of dampness on the inner surface of the substrate other than that caused solely by condensation.

10.2 Designers and installers should take particular care in detailing around openings, penetrations and movement joints to minimise the risk of water ingress.

10.3 The guidance given in BRE Report BR 262 : 2002 should be followed in connection with the watertightness of solid wall constructions. The designer should select a construction appropriate to the local wind-driven index, paying due regard to the design detailing, workmanship and materials to be used.

10.4 At the top of walls, the systems should be protected by an adequate overhang or other detail designed for use with this type of system (see section 16).

11 Risk of condensation



11.1 Designers must ensure that an appropriate condensation risk analysis has been carried out for all parts of the construction, including openings and penetrations at junctions between the insulation system and windows, to minimise the risk of condensation. The recommendations of BS 5250 : 2011 should be followed.

Surface condensation



11.2 Walls will adequately limit the risk of surface condensation when the thermal transmittance (U value) does not exceed $0.7 \text{ W}\cdot\text{m}^{-2}\cdot\text{K}^{-1}$ at any point and the junctions with other elements and openings comply with section 6.3 of this Certificate.



11.3 Walls will adequately limit the risk of surface condensation when the thermal transmittance (U value) does not exceed $1.2 \text{ W}\cdot\text{m}^{-2}\cdot\text{K}^{-1}$ at any point. Guidance may be obtained from BS 5250 : 2011, section 4 and Annex G, and BRE Report BR 262 : 2002.

Interstitial condensation



11.4 Walls incorporating the systems will adequately limit the risk of interstitial condensation when they are designed and constructed in accordance with BS 5250 : 2011, section 4 and Annexes D and G.

11.5 The water vapour resistance factor (μ) for the insulation boards and equivalent air layer thickness (s_d) (for the render systems) is shown in Table 9 of this Certificate.

Table 9 Water vapour resistance factor and equivalent air layer thickness

	Thickness (mm)	s_d (m)	μ
Expanded polystyrene – white and grey EPS 70	50 to 300	–	20 to 40 ⁽¹⁾
Expanded polystyrene – white EPS 120	50 to 300	–	50
Phenolic (PHS)	20 to 200	–	50
Polyisocyanurate (PIR)	50 to 150	–	60
Rendering system:			
Basecoat + finish coat + decorative coat, as indicated below			
Klebocem + TermoK8 Rivatone Plus	1.5 to 3	0.472	–
TermoK8 Rivatone Idrosiliconico Plus	1.2 to 3	0.316	–
Rendering system:			
Klebocem Grosso basecoats	6 to 7	0.9	
Brick effect render base + Brick effect render top	8 to 14	0.20	–
Dash receiver + Spar dash aggregate	9 to 14	1.0	–
Clay brick-slips	8 to 15	0.30 to 0.75	50 to 37
Acrylic brick-slips adhesive + Acrylic brick-slips	6 to 8	0.19	–

(1) It is recommended that the lower figure is used when assessing the interstitial condensation risk.

(2) To be determined in each case.

12 Maintenance and repair



12.1 Regular checks should be made on the installed systems, including:

- visual inspection of the render for signs of damage. Cracks in the render exceeding 0.2 mm must be repaired
- examination of the sealant around openings and service entry points
- visual inspection of architectural details designed to shed water to confirm that they are performing properly
- visual inspection to ensure that water is not leaking from external downpipes or gutters; such leakage could penetrate the rendering
- necessary repairs effected immediately and the sealant joints at window and door frames replaced at regular intervals
- maintenance schedules, which should include the replacement and resealing of joints, for example between the insulation system and window and door frame.

12.2 Damaged areas must be repaired using the appropriate components and procedures detailed in the Certificate holder's installation instructions and in accordance with BS EN 13914-1 : 2005.

13 Durability



13.1 The systems will have a service life of at least 30 years provided any damage to the surface finish is repaired immediately and regular maintenance is undertaken, as described in section 12.

13.2 The systems' service life can extend to 60 years provided the chosen system is fixed through the reinforcement mesh and a planned inspection and maintenance programme is introduced in accordance with Section 12. An extended 60-years' service life requires the use of stainless steel base and corner profiles, stainless steel centre pin fixings [304 Grade (1.4301)] and plastic anchor sleeve materials such as polyamide (PA6 and PA6.6), polyethylene (PE) or polypropylene (PP) and following an appropriate repair and maintenance schedule as covered by the Certificate holder's repair and maintenance manual. Any damage to the surface finish must be repaired within a time period agreed by the Certificate holder.

13.3 Any render containing cement may be subject to lime bloom. The occurrence of this may be reduced by avoiding application in adverse weather conditions. The effect is transient and less noticeable on lighter colours.

13.4 The render may become discoloured with time, the rate depending on the initial colour, the degree of exposure and atmospheric pollution, as well as the design and detailing of the wall. In common with traditional renders, discoloration by algae and lichens may occur in wet areas. The appearance may be restored by a suitable power wash or, if required, by over coating.

13.5 To maintain a high quality aesthetic appearance, it may be necessary to periodically overcoat the building using a suitable masonry coating (ie one covered by a valid BBA Certificate for this purpose). Care should be taken not to adversely affect the water vapour transmission or fire characteristics of the system. The advice of the Certificate holder should be sought as to the suitability of a particular product.

Installation

14 Site survey and preliminary work

14.1 A pre-installation survey of the property must be carried out to determine suitability for treatment and the need for any necessary repairs to the building structure before application of the system. A specification is prepared for each elevation of the building indicating:

- additional corner mesh and reinforcement, where required
- the position of beads
- detailing around windows, doors and at eaves
- damp-proof course (dpc) level (not covered by this Certificate)
- exact position of expansion joints
- areas where flexible sealants must be used
- where required, the position of fire barriers.

14.2 The survey should include tests conducted on the walls of the building by the Certificate holder or their approved installers to determine the pull-out resistance of the proposed mechanical fixings. An assessment and recommendation is made on the type and number of fixings required to withstand the building's expected wind loading based on calculations using the test data and pull-out resistance (see section 7).

14.3 All necessary repairs to the building structure must be completed before installation of the system commences.

14.4 Surfaces should be sound, clean, and free from loose material. The flatness of surfaces must be checked; this may be achieved using a straight-edge spanning the storey height. Any excessive irregularities, ie greater than 20 mm, must be made good prior to installation, to ensure that the insulation boards are installed with a smooth, in-plane finished surface.

14.5 Where surfaces are covered with an existing rendering, it is essential that the bond between the background and the render is adequate. All loose areas should be hacked off and reinstated.

14.6 On existing buildings, purpose-made sills must be fitted to extend beyond the finished face of the system. New buildings should incorporate suitably deep sills.

14.7 Internal wet work, eg screeding or plastering, should be completed and allowed to dry prior to the application of a system.

15 Approved installers

Application of the systems, within the context of this Certificate, must be carried out by installers approved by the Certificate holder. A Certificate holder approved installer is a company:

- employing operatives who have been trained and approved by the Certificate holder to install the system
- which has undertaken to comply with the Certificate holder's application procedure, containing the requirement for each application team to include at least one member operative trained by the Certificate holder
- subject to at least one inspection per annum by the Certificate holder to ensure suitable site practices are being employed. This may include unannounced site inspections.

16 Procedure

General

16.1 Installation of the systems must be carried out in accordance with the Certificate holder's installation instructions.

16.2 Weather conditions should be monitored to ensure that the circumstances under which application and curing of the systems take place are favourable. Application of the mortar and finishes should not be carried out at temperatures below 5°C or above 35°C, or if exposure to frost is likely. The coating must be protected from rapid drying.

16.3 All rendering should be in accordance with the relevant recommendations of BS EN 13914-1 : 2005.

16.4 The initial installation procedure is common to both systems (see section 1.1).

Positioning and securing insulation boards

16.5 The base profile is secured to the external wall above the dpc using the approved profile fixings at approximately 300 mm centres (see Figure 3). Starter track connectors are inserted at all rail joints. Extension profiles are fixed to the front lip of the starter track or stop end channel where appropriate. Note: For a 60-year durability application, the starter track needs to be constructed using stainless steel material.

Figure 3 Typical section of base profile

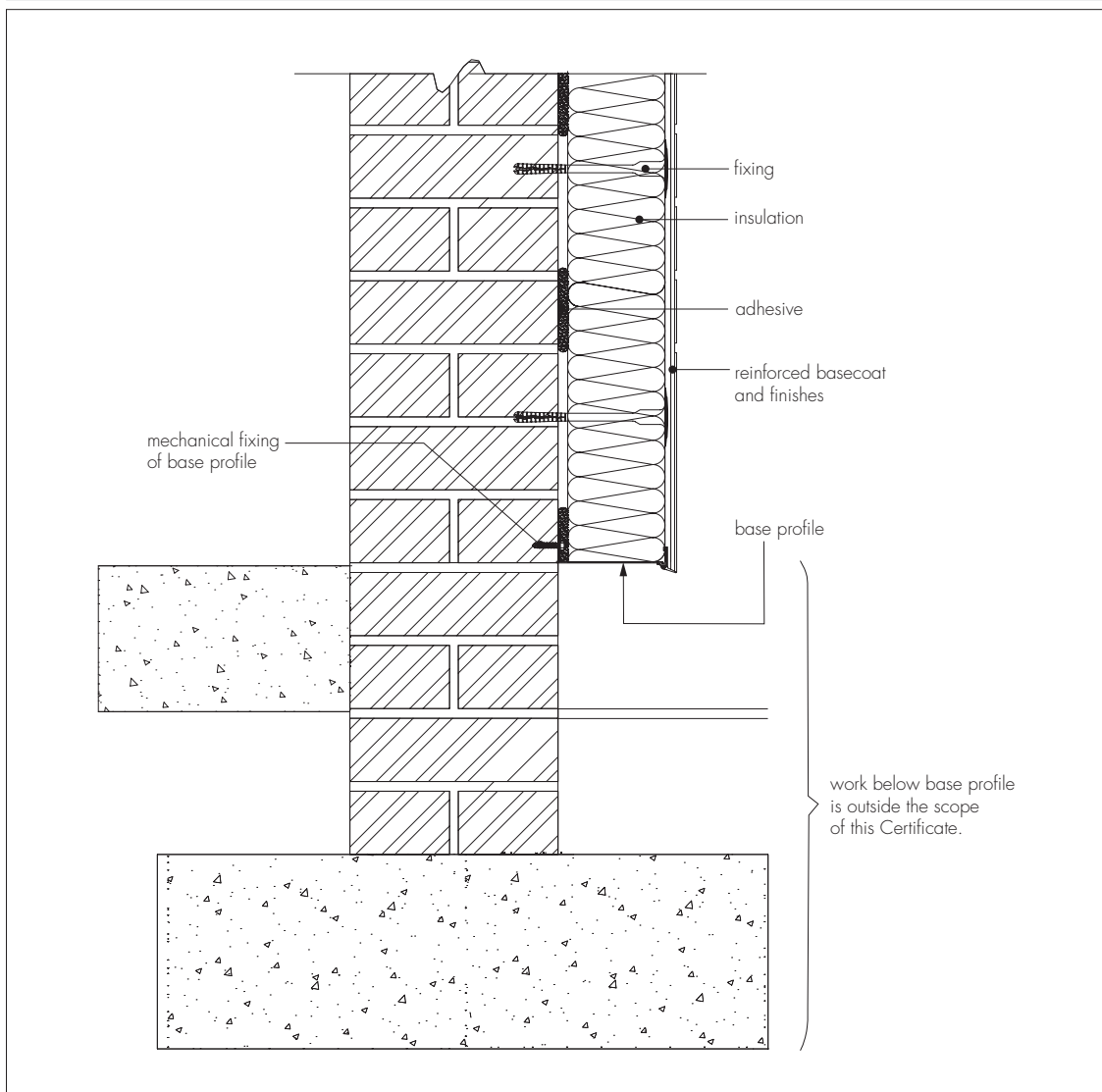

16.6 The supplementary adhesive is prepared with the required amount of water (see section 1.3), and mixed with a paddle mixer until the desired consistency is achieved. After allowing the adhesive to rest for 5 minutes, it is applied in a continuous bordering strip around the perimeter of the board with three additional dabs of approximate width between 10 mm and 40 mm distributed uniformly over the remaining surface. Alternatively a serrated edge trowel with 5 mm serrations can be used to apply the adhesive to the entire rear surface of the insulation board.

16.7 The first run of insulation boards is positioned on the base profile with the adhesive applied. The boards must be pressed firmly against the wall and butted tightly together and aligned to achieve a level finish. Subsequent rows of boards are positioned so that the vertical board joints are staggered and overlapped at the building corners and so that the board joints do not occur within 200 mm of the corners of openings (see Figure 4). Joints between boards greater than 2 mm should be filled with slivers of insulation board or low density polyurethane foam. Gaps greater than 10 mm should be closed by repositioning or, where appropriate, by cutting boards to fit. Any high spots or irregularities should be removed. Alignment should be checked as work proceeds

Figure 4 Typical arrangement of insulation boards

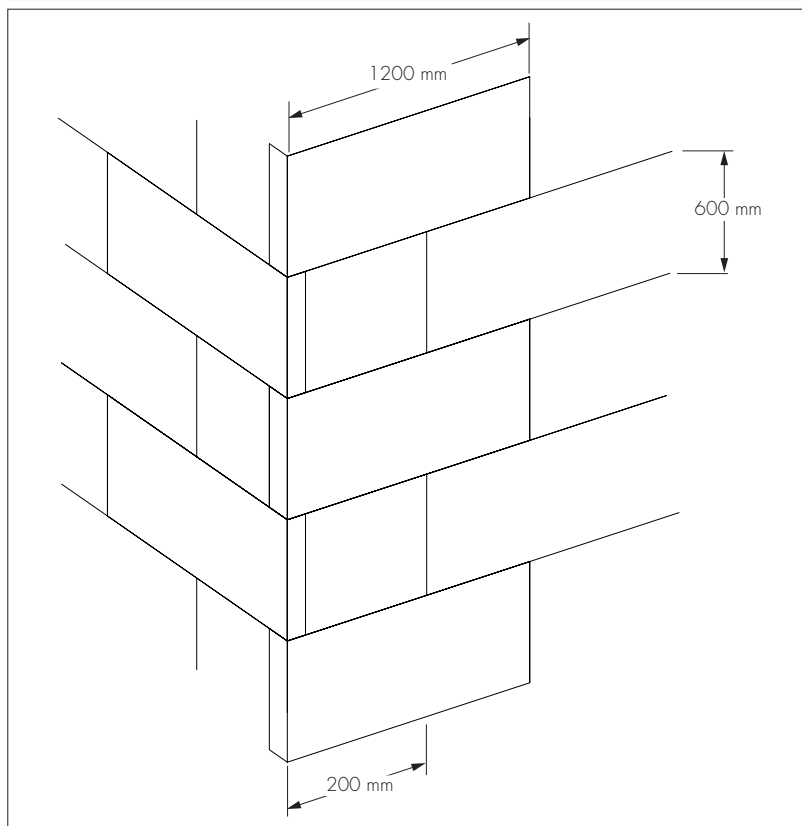

16.8 To fit around details such as doors and windows, insulation boards may be cut with a sharp knife or a fine toothed saw. If required, purpose-made window-sills are fitted at this stage. They are designed to prevent water ingress and incorporate drips to shed water clear of the system.

16.9 Installation continues until the whole wall is completely covered including, where appropriate, the building soffits.

16.10 Window and door reveals should be insulated to minimise the effects of cold bridging. Where clearance is limited, strips of approved insulation should be installed to suit available margins and details.

16.11 Prior to the application of the basecoat render, a bead of joint sealant is gun-applied at window and door frames, overhanging eaves, gas and electric meter boxes, and wall vents, or where the render abuts any other building material or surface.

Movement joints

16.12 Generally, movement joints are not required in the systems but, if an expansion joint is already incorporated in the substrate, a movement joint must be included with the system (see Figure 5). Specific types of joint have not been assessed as part of these systems and advice should be sought from the Certificate holder.

Figure 5 Typical movement joint

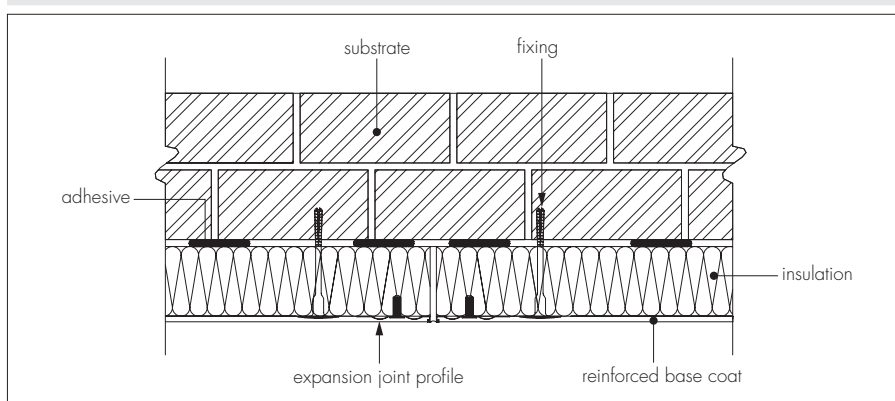

16.13 Prior to the application of the render and mesh, pieces of reinforcing mesh (approximate size 350 mm by 250 mm) should be used diagonally at the corners of windows and doors and other building openings so that they extend equally either side of the corner (see Figure 6).

Figure 6 Reinforcement at openings

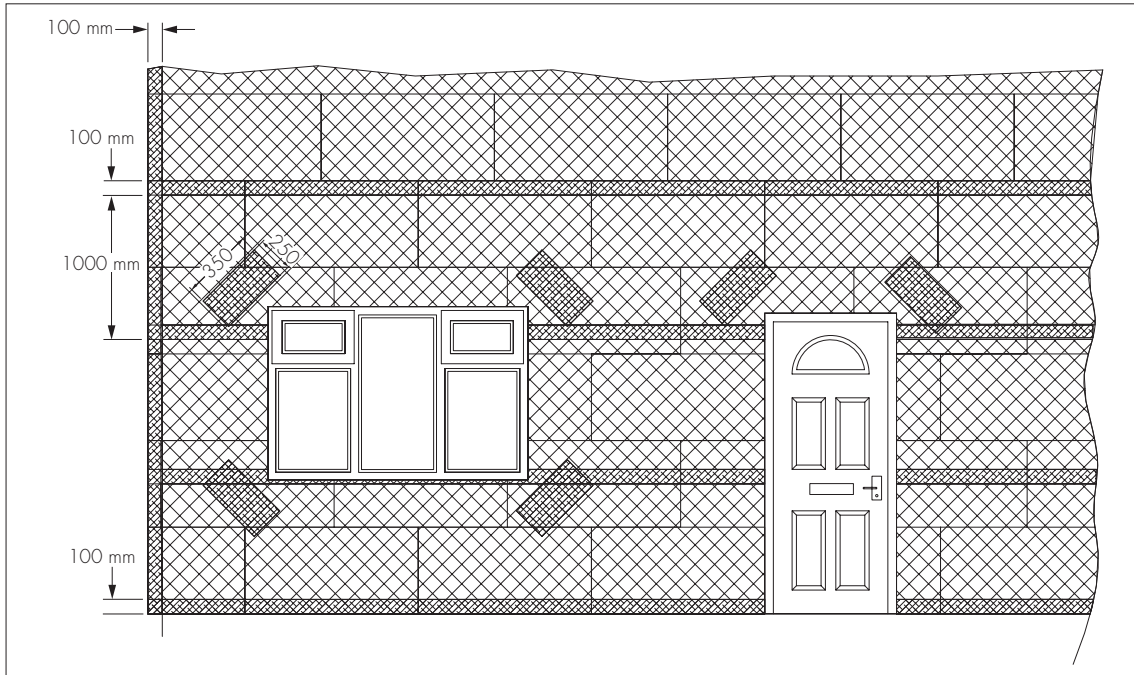

Application of 30-year durability system – mechanical fixings through the insulation boards

16.14 For a 30-year durability, the boards are adhesively fixed to the substrate and holes are drilled into the substrate through the insulation board in a 'saltire' fixing pattern to a specified minimum depth. Mechanical fixings are applied through each insulation board to an equivalent of seven fixings per m² (see Figure 7). The mechanical fixings are tapped firmly into place, securing the insulation to the substrate.

Figure 7 30-years durability fixings pattern

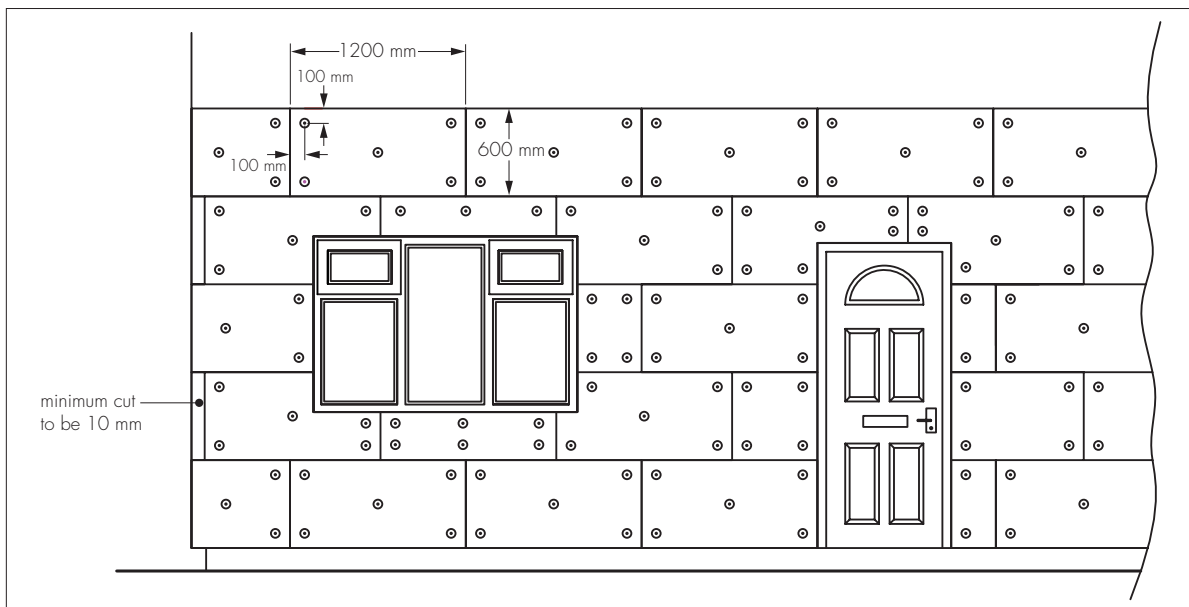

16.15 The basecoat is prepared with the required amount of water (see section 1.3), then applied over the insulation boards using a stainless steel trowel, and floated with a Darby float to an approximate 3 mm thickness. The reinforcement mesh is immediately embedded into the basecoat by trowelling from the centre to the edge and an additional light coat of basecoat is applied (while the first coat is still wet) to ensure the mesh is free of wrinkles; overlapping at all mesh joints should not be less than 100 mm. The first basecoat is allowed to cure for 48 hours before applying the second basecoat.

16.16 Further basecoat is then applied as required, to ensure the mesh is completely covered and the required overall minimum 6 mm thickness of basecoat is achieved.

16.17 The basecoat is applied progressively, working in one-metre sections in a vertical or horizontal direction. The application of the basecoat render continues, following the procedures in section 16.23.

Application of 60-year durability system — mechanical fixings through the mesh boards

16.18 Two mechanical fixings are applied through each insulation board to secure them during installation of the system. Holes are drilled through the insulation board into the substrate wall and mechanical fixings are inserted and tapped or screwed firmly into place.

16.19 The basecoat is trowel applied to the surface of the insulation to a thickness of 3 mm.

16.20 Reinforcement mesh is immediately applied and embedded into the basecoat using the trowel, and overlapped at all mesh joints by not less than 100 mm.

16.21 It is important to ensure that the mesh is free of wrinkles, completely covered and that the required minimum thickness of basecoat is achieved.

16.22 While the basecoat is still wet, holes are drilled through the reinforcement mesh and insulation boards into the substrate wall to the required depth at the specified frequency and pattern, but not less than seven fixings per square metre. Around openings, additional fixings should be used at 300 mm centres. The mechanical fixings are inserted and tapped or screwed firmly into place, securing the mesh and insulation boards to the substrate wall.

Figure 8 60-years durability fixings pattern

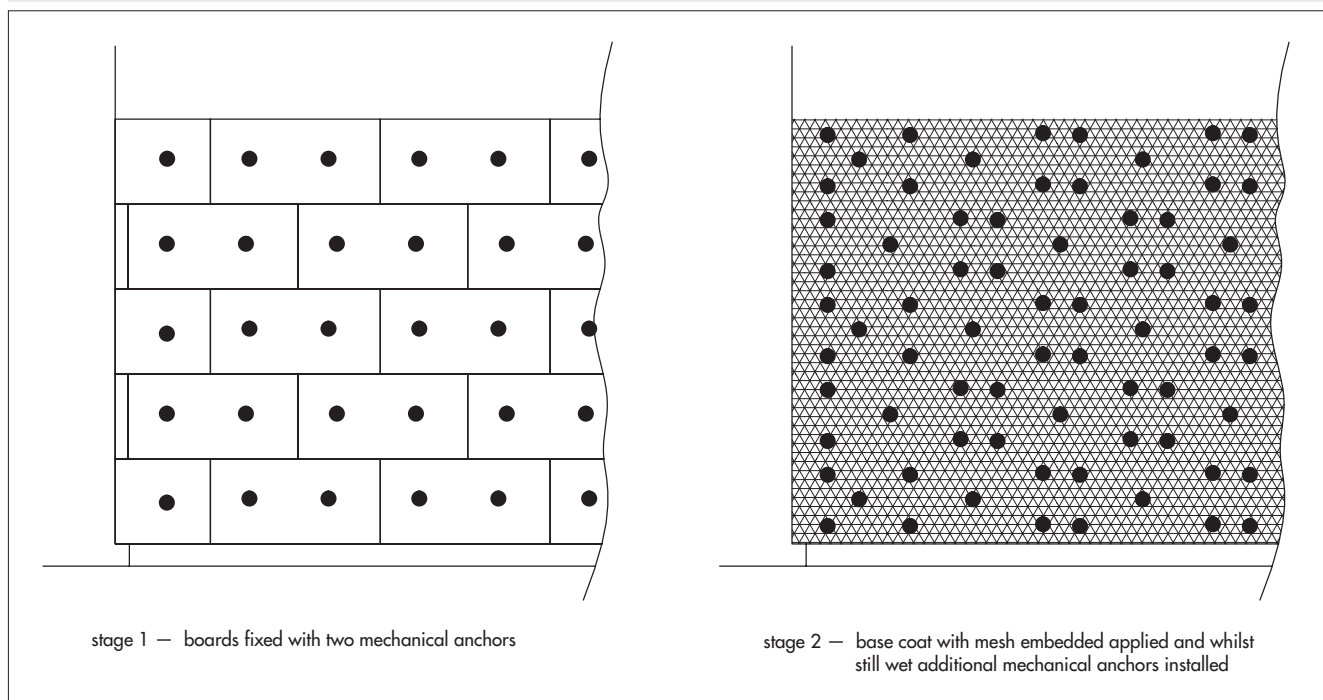

16.23 The fixings are slightly overdriven into the substrate in order to allow the fixing plate to partially penetrate through the basecoat and insulation boards.

16.24 While the basecoat is still wet, 200 mm by 200 mm stress patches of reinforcing mesh are applied over the head of the fixings and fully embedded with the basecoat. Further basecoat is then applied to maintain a minimum of approximately 4 mm thickness when measured from the top of the fixing head.

16.25 The basecoat is applied progressively, working in one-metre sections in a vertical or horizontal direction.

16.26 Stop beads are positioned vertically, eg at party wall positions where the adjoining house does not require treatment. Where required, angle beads are fixed to all building corners and to door and window heads and jambs.

16.27 Once the application of the basecoat is completed, the basecoat (with the embedded mesh) is left to dry. The drying time will depend upon the weather conditions, but a minimum of 48 hours should elapse before the finishes are applied.

Finish coats

16.28 The finish coating must be trowel- or roller-applied to give the appropriate texture effect and applied to the required thicknesses (see section 1), using a stainless steel trowel and finished with a plastic trowel to create a textured finish. The drying time is dependent on conditions, but will typically be 48 hours in accordance with the Certificate holder's instructions.

16.29 To prevent the finish from drying too rapidly, it should not be applied in direct sunlight. The finished render surface must be protected from rain and frost until the material is dry. Continuous surfaces must be completed without a break, eg working to a wet edge.

Top coats

Dash receiver and Spar aggregates

16.30 The dash receiver is prepared by mixing each 25 kg bag with 4.5 to 5 litres of clean water. The product is mixed thoroughly to the specified consistency. It is applied to a depth of 6 mm, to achieve an even coat using straight edges and spatulas if necessary. A thicker coat of dash receiver may be necessary when using a larger aggregate size to ensure it fully beds into the dash receiver. While the receiver is still soft, selected clean spar aggregates are applied onto the surface.

16.31 Aggregates should be cleaned and dampened before dashing onto the dash receiver.

16.32 On completion, the surface must be checked to ensure an even coverage of the spar-dash has been achieved. Where necessary the aggregate should be lightly tamped to ensure that a good bond is achieved.

Brick effect render base and top coats

16.33 The brick effect render base is prepared by mixing each 25 kg bag with 4 to 5 litres of clean water. The product is mixed thoroughly to the specified consistency, for a minimum of 5 minutes using an electric paddle mixer to disperse the additives

16.34 The brick effect base layer should be applied to the surface of the basecoat using a hawk and trowel or projection render machine to a minimum thickness of 6 mm and ruled off to a flat finish.

16.35 After the base layer has started to stiffen, a second layer of brick-effect render top is applied to the brick-effect base render using a hawk and trowel, or projection render machine.

16.36 The brick effect top render pattern is achieved using various tamping blocks or stiff brushes. It should be cut out to the required pattern after the top layer has been shaded and textured. The top layer is cut through completely until it penetrates the base layer slightly, using an appropriate bespoke cutting tool. This reproduces recessed mortar coursing of the brickwork as required.

16.37 Following further stiffening of the materials, any face material left by the cutting out should be lightly brushed and removed using a soft bristled brush, allowing it to thoroughly dry out for 48 hours to 1 week depending on weather conditions.

Acrylic brick-slips adhesive + Acrylic brick-slips

16.38 Acrylic primer is applied by roller or brush. The primer is allowed to dry at least 24 hours before application of the acrylic brick-slip adhesive, which is applied by a 5 mm notch trowel to the entire surface of the primed basecoat, in workable sections.

16.39 Acrylic brick-slips are applied by hand in a brick bond fashion, lined and levelled into adhesive. Joints are normally 10 mm wide and, when pointing, a suitably-sized brush is used to smooth out the adhesive once it has stiffened into the joints. Acrylic brick-slips can be subject to shade variations; they should, therefore, be selected at random from different boxes.

16.40 At the top of walls, the systems should be protected by an adequate overhang (see Figure 9) or by an adequately sealed purpose-made flashing. Care should be taken in the detailing of the system around openings and projections (see Figures 10, 11 and 12).

Figure 9 Typical roof eaves detail

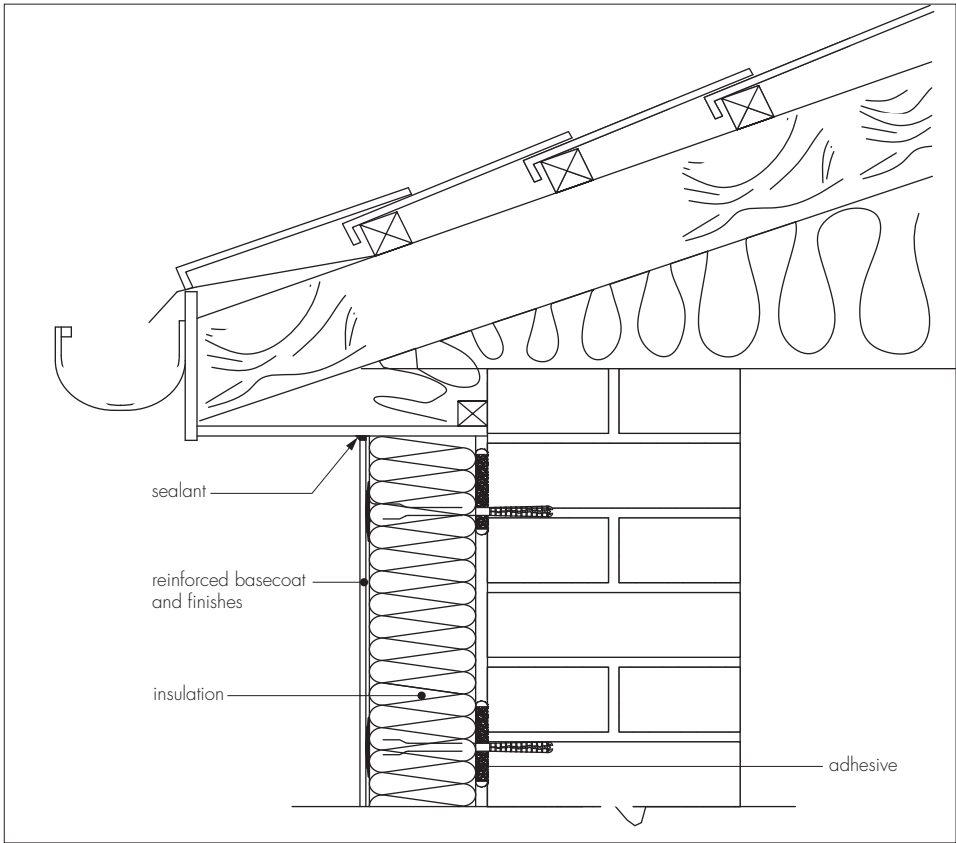

Figure 10 Window head details

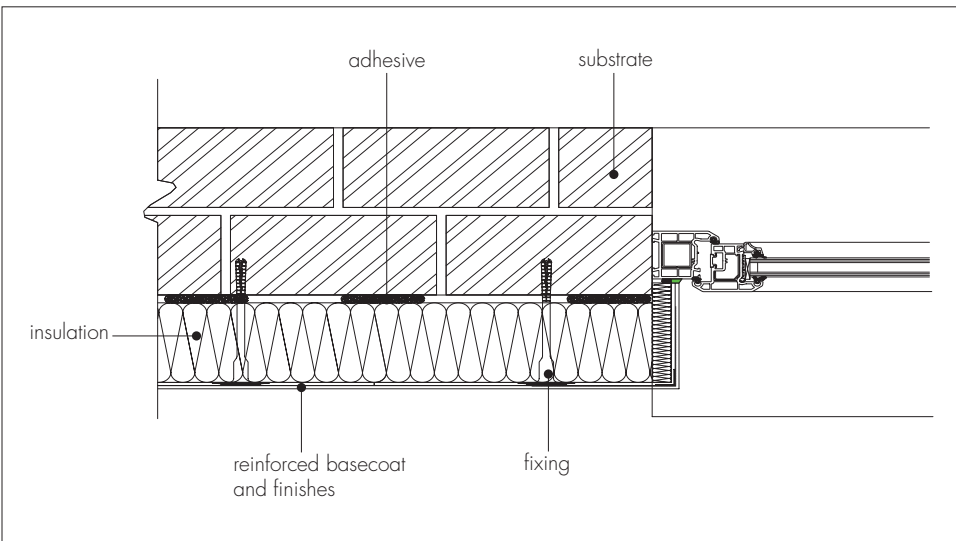

Figure 11 Corner details

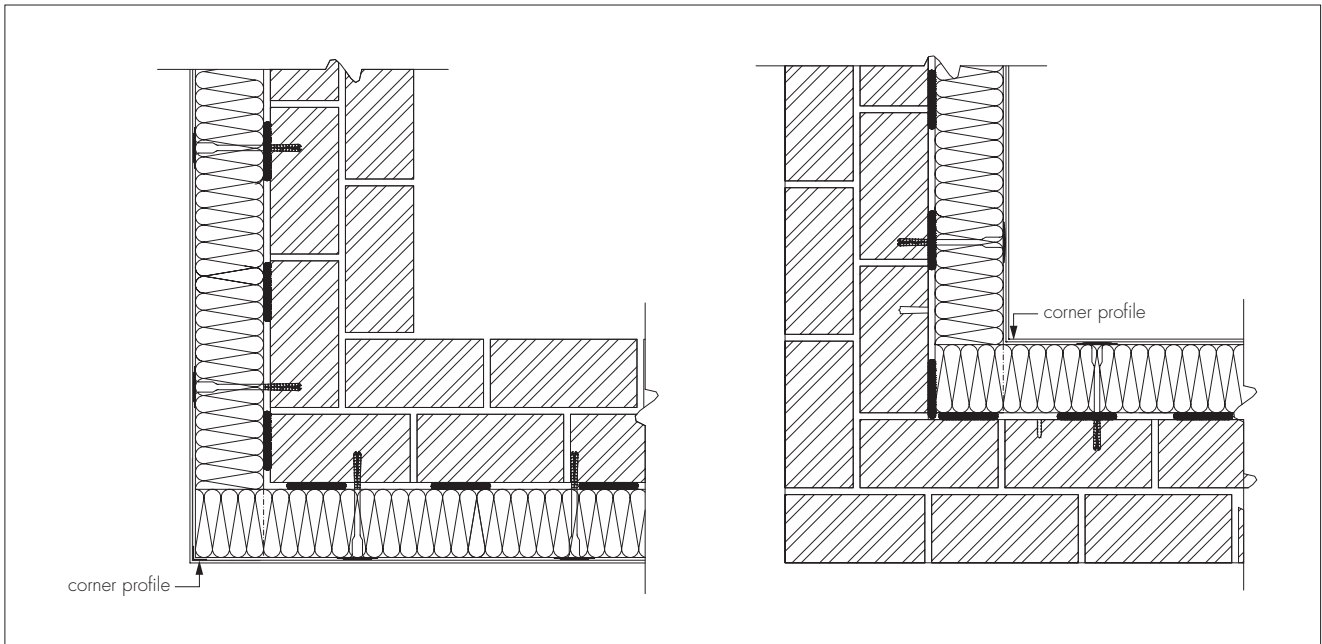
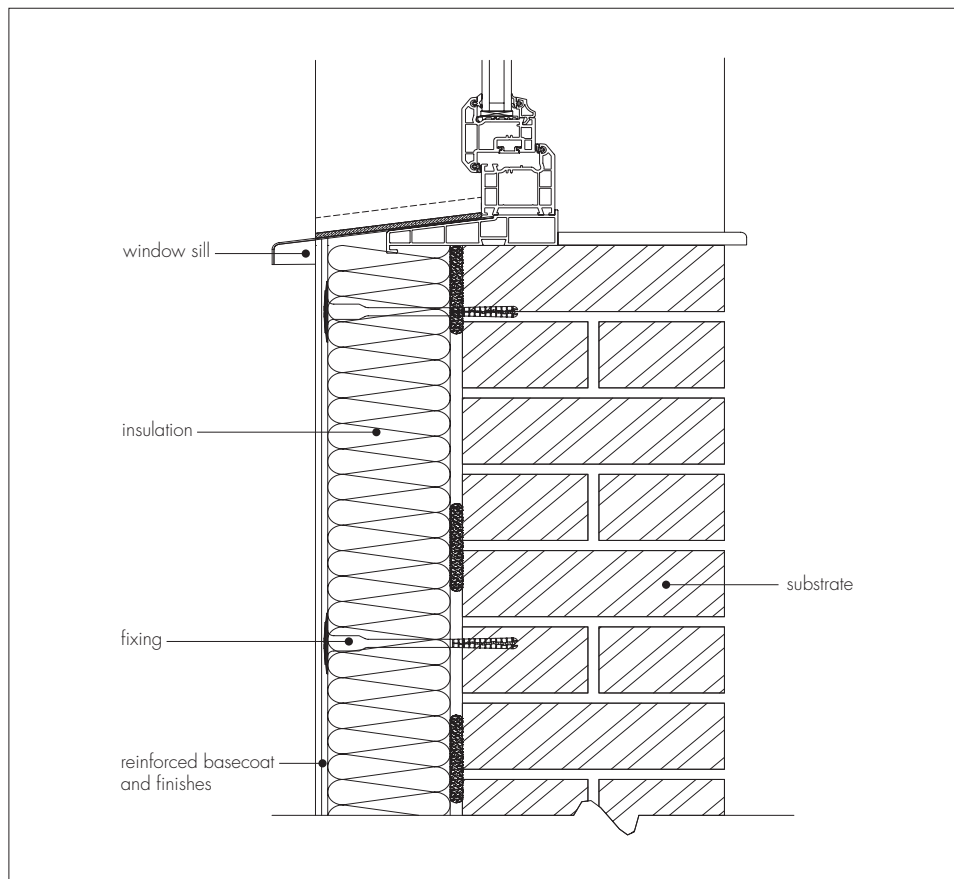

Figure 12 Window sill details



16.41 On completion of the installation, external fittings, eg rainwater goods, are re-fixed through the system into the substrate.

17 Tests

17.1 The system was examined and assessed to determine:

- reaction-to-fire class in accordance with BS EN 13501-1 : 2007
- bond strength
- hygrothermal performance
- resistance to frost
- resistance to impact
- water vapour permeability
- thermal conductivity
- the risk of interstitial condensation.

17.2 The practicability of installation and the effectiveness of detailing techniques were examined.

17.3 The manufacturing process was evaluated, including the methods adopted for quality control, and details were obtained of the quality and composition of materials used.

Bibliography

- BS 5250 : 2011 *Code of practice for control of condensation in buildings*
- BS 8000-3 : 2001 *Workmanship on building sites — Code of practice for masonry*
- BS EN 197-1 : 2011 *Cement — Composition, specifications and conformity criteria for common cements*
- BS EN 771-1 : 2011 *Specification for masonry units — Clay masonry units*
- BS EN 1990 : 2002 *Eurocode — Basis of structural design*
- BS EN 1991-1-4 : 2005 *Eurocode 1 — Actions on structures — General actions — Wind actions*
- BS EN 1996-2 : 2006 *Eurocode 6 — Design of masonry structures — Design considerations, selection of materials and execution of masonry*
- BS EN 13139 : 2002 *Aggregates for mortar*
- BS EN 13163 : 2012 *Thermal insulation products for buildings. Factory made expanded polystyrene (EPS) products — Specification*
- BS EN 13165 : 2012 *Thermal insulation products for buildings. Factory made rigid polyurethane foam (PU) products. Specification*
- BS EN 13166 : 2012 *Thermal insulation products for buildings — Factory made phenolic foam (PF) products — Specification*
- BS EN 13501-1 : 2007 *Fire classification of construction products and building elements — Classification using test data from reaction to fire tests*
- BS EN 13914-1 : 2005 *Design, preparation and application of external rendering and internal plastering — External rendering*
- BS EN ISO 6946 : 2007 *Building components and building elements — Thermal resistance and thermal transmittance — Calculation method*
- BS EN ISO 11600 : 2003 *Building construction — Jointing products — Classification and requirements for sealants*
- BRE Report (BR 443 : 2006) *Conventions for U-value calculations*
- ETAG 004 : 2013 *Guideline for European Technical Approval of External Thermal Insulation Composite Systems with Rendering*
- ETAG 014 : 2011 *Guideline for European Technical Approval of Plastic Anchors for fixing of External Thermal Insulation Composite Systems with Rendering*
- BRE Report (BR 135 : 2013) *Fire performance of external insulation of walls of multistorey buildings*
- BRE Report (BR 262 : 2002) *Thermal insulation: avoiding risks*
- BRE Report (BR 443 : 2006) *Conventions for U-value calculations*

18 Conditions

18.1 This Certificate:

- relates only to the product/system that is named and described on the front page
- is issued only to the company, firm, organisation or person named on the front page — no other company, firm, organisation or person may hold or claim that this Certificate has been issued to them
- is valid only within the UK
- has to be read, considered and used as a whole document — it may be misleading and will be incomplete to be selective
- is copyright of the BBA
- is subject to English Law.

18.2 Publications, documents, specifications, legislation, regulations, standards and the like referenced in this Certificate are those that were current and/or deemed relevant by the BBA at the date of issue or reissue of this Certificate.

18.3 This Certificate will remain valid for an unlimited period provided that the product/system and its manufacture and/or fabrication, including all related and relevant parts and processes thereof:

- are maintained at or above the levels which have been assessed and found to be satisfactory by the BBA
- continue to be checked as and when deemed appropriate by the BBA under arrangements that it will determine
- are reviewed by the BBA as and when it considers appropriate.

18.4 The BBA has used due skill, care and diligence in preparing this Certificate, but no warranty is provided.

18.5 In issuing this Certificate, the BBA is not responsible and is excluded from any liability to any company, firm, organisation or person, for any matters arising directly or indirectly from:

- the presence or absence of any patent, intellectual property or similar rights subsisting in the product/system or any other product/system
- the right of the Certificate holder to manufacture, supply, install, maintain or market the product/system
- actual installations of the product/system, including their nature, design, methods, performance, workmanship and maintenance
- any works and constructions in which the product/system is installed, including their nature, design, methods, performance, workmanship and maintenance
- any loss or damage, including personal injury, howsoever caused by the product/system, including its manufacture, supply, installation, use, maintenance and removal
- any claims by the manufacturer relating to CE marking.

18.6 Any information relating to the manufacture, supply, installation, use, maintenance and removal of this product/system which is contained or referred to in this Certificate is the minimum required to be met when the product/system is manufactured, supplied, installed, used, maintained and removed. It does not purport in any way to restate the requirements of the Health and Safety at Work etc. Act 1974, or of any other statutory, common law or other duty which may exist at the date of issue or reissue of this Certificate; nor is conformity with such information to be taken as satisfying the requirements of the 1974 Act or of any statutory, common law or other duty of care.